





Slido

gilt für Artikel: siehe Tabell
 applies to Cat. No.: see table
 valable pour référence : voir table
 adecuado para N° de ref.: ver table

Classic F Holz/wood/bois/ de madera	0 	2 
40-F		940.67.016
50-F	940.67.506 940.67.014 940.67.507 940.67.508	940.67.509 940.67.511 940.67.510 940.67.015

i

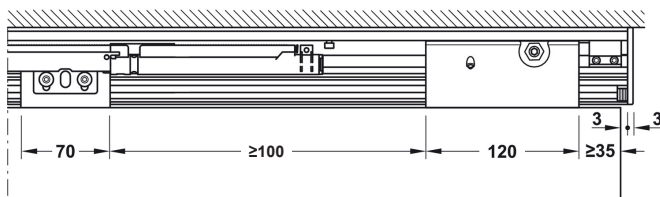
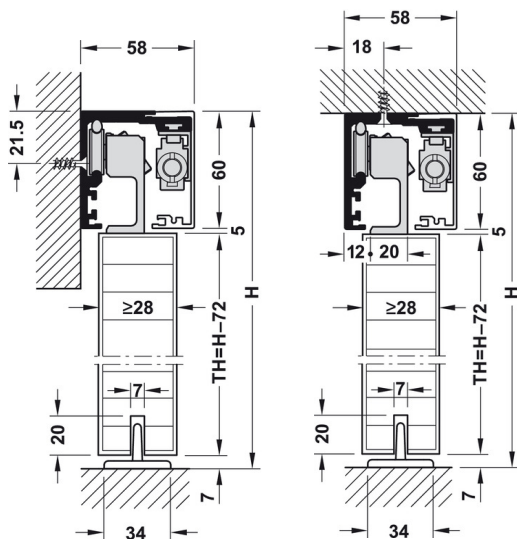

i

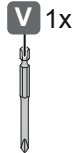
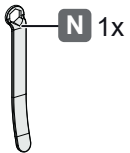
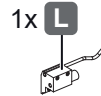
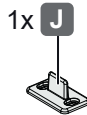
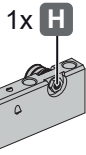
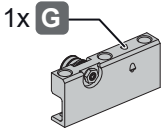
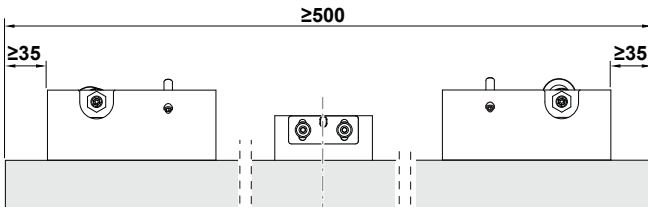
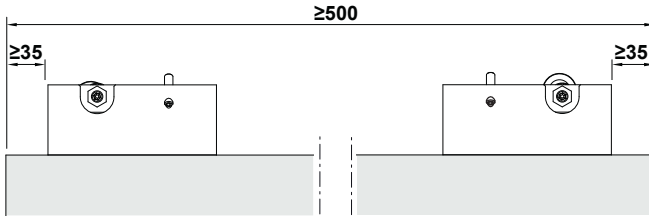

+

2

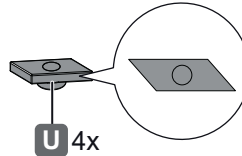
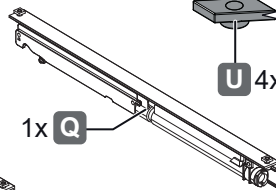
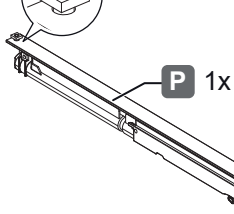
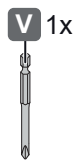
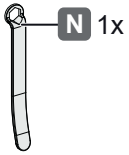
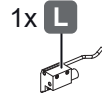
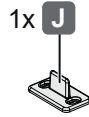
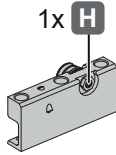
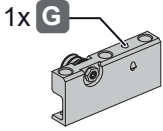
4x **U**

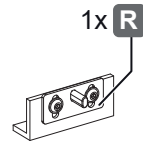

+

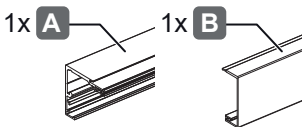

+

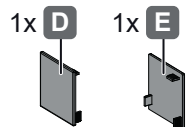

1

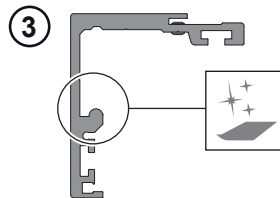
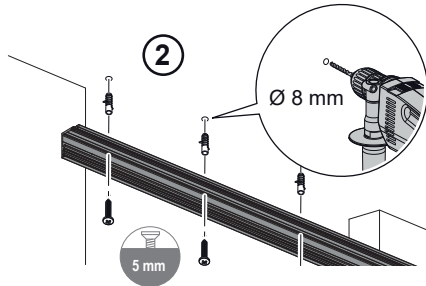
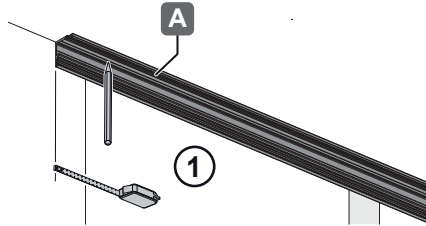
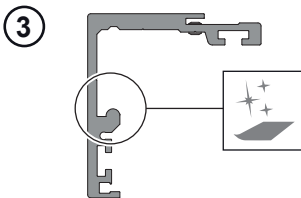
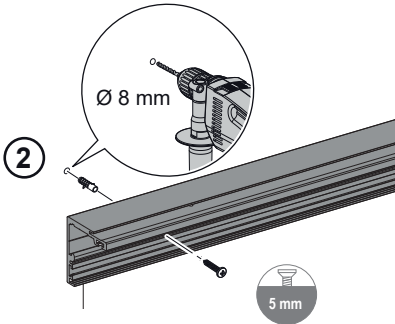
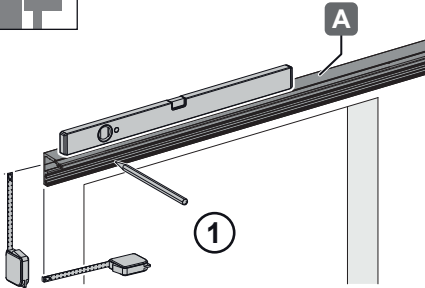

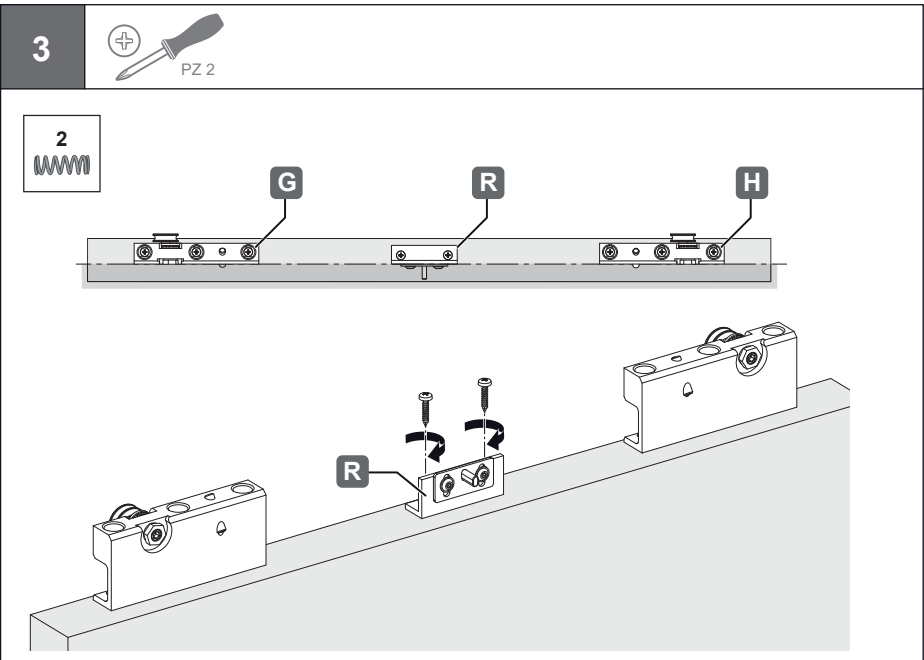
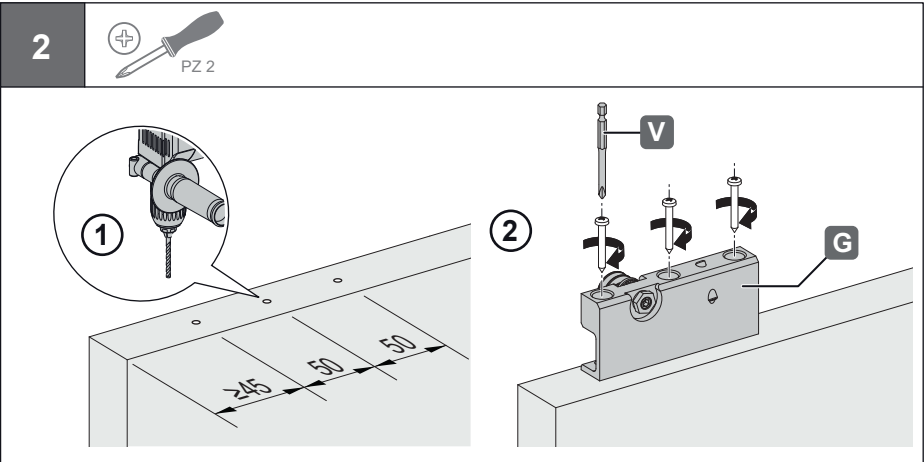

4

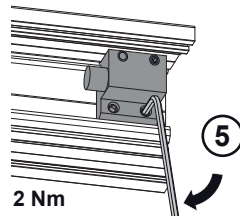
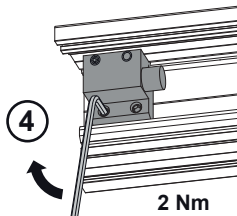
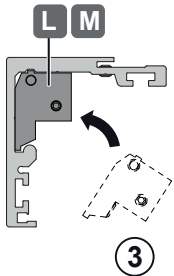
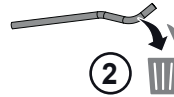
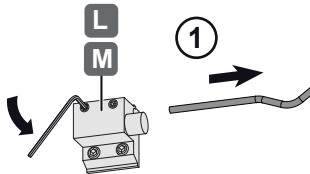
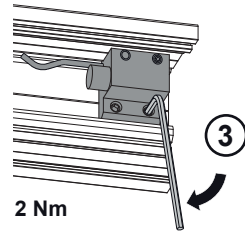
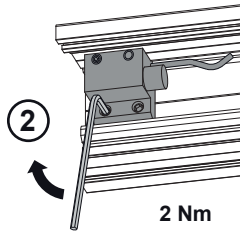
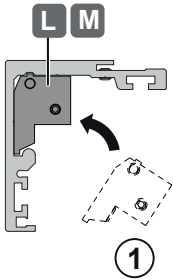

5

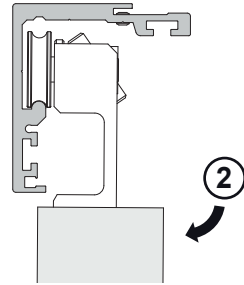
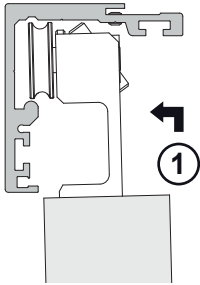

6

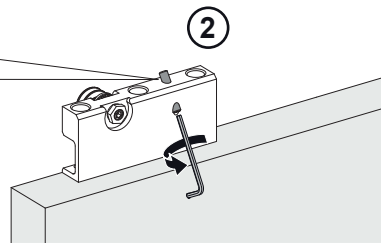
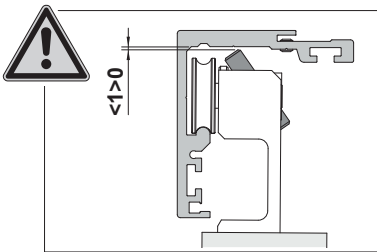
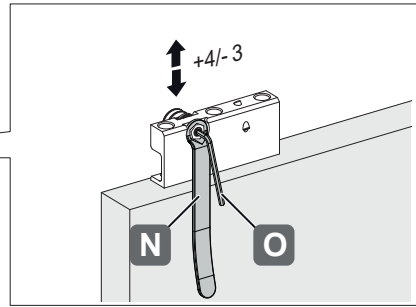
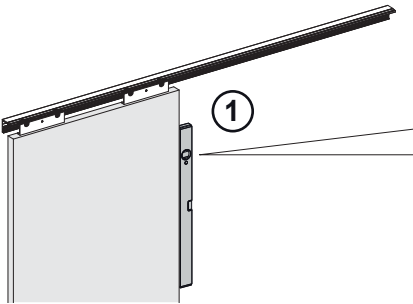

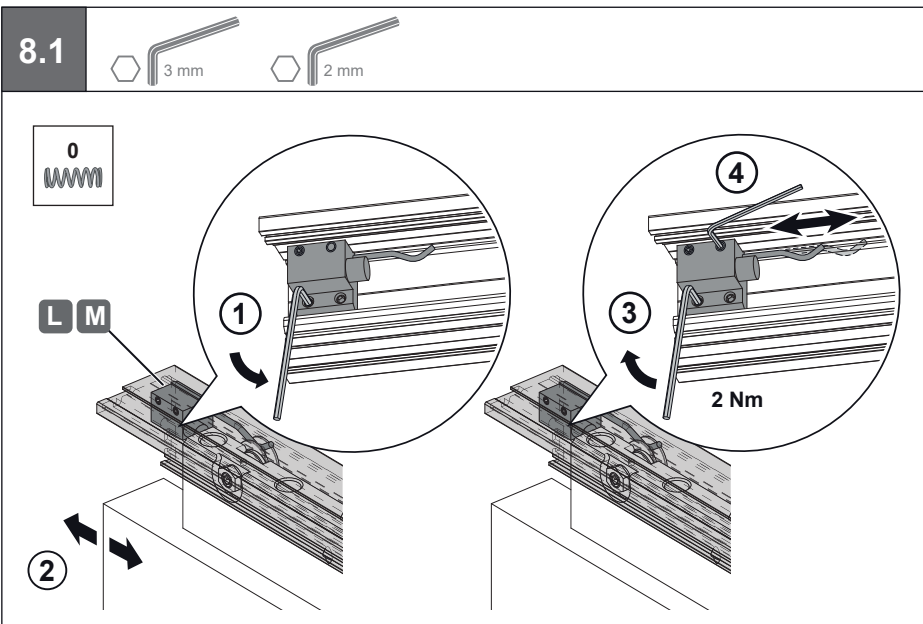
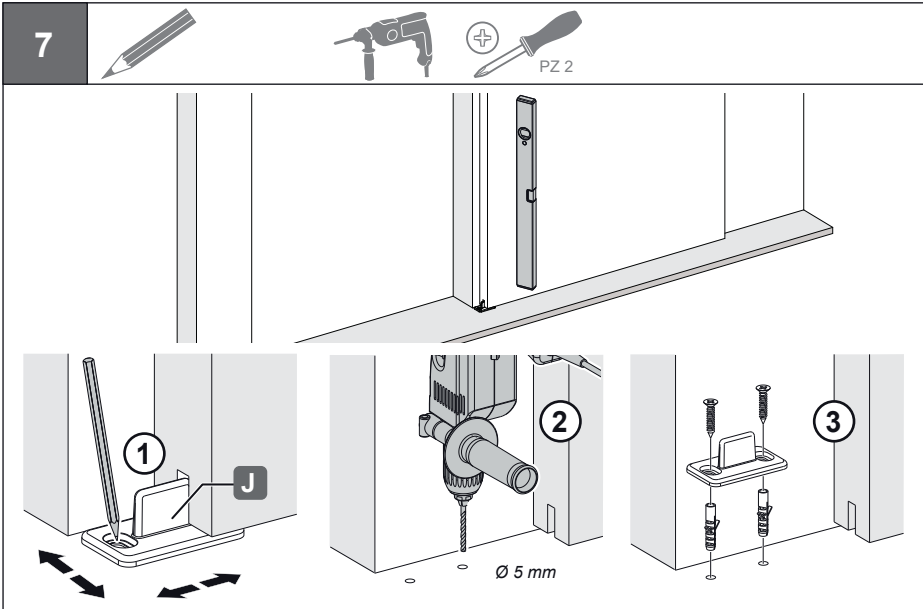

8.2

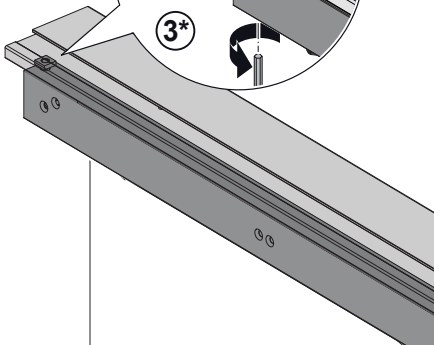
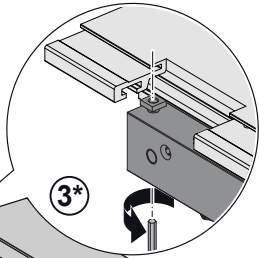
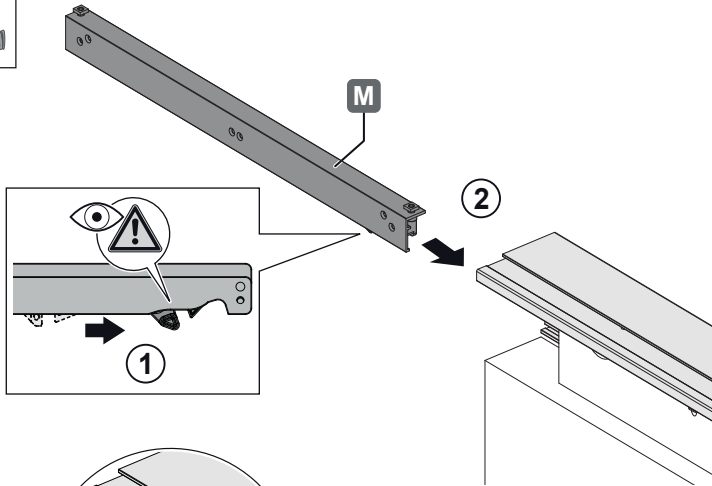

- * Nur leicht anziehen, der Dämpfer muss noch beweglich bleiben!
- * Only tighten slightly, the damper must still move!
- * Ne serrez que légèrement, l'amortisseur doit encore bouger !
- * Sólo apriete ligeramente, el amortiguador debe seguir moviéndose!

8.2



2



Optional: Für eine nachträgliche Montage von unten.
 Optional: For retrofitting from below.
 En option : pour un montage ultérieur par le bas.
 Opcional: para el reequipamiento desde abajo.

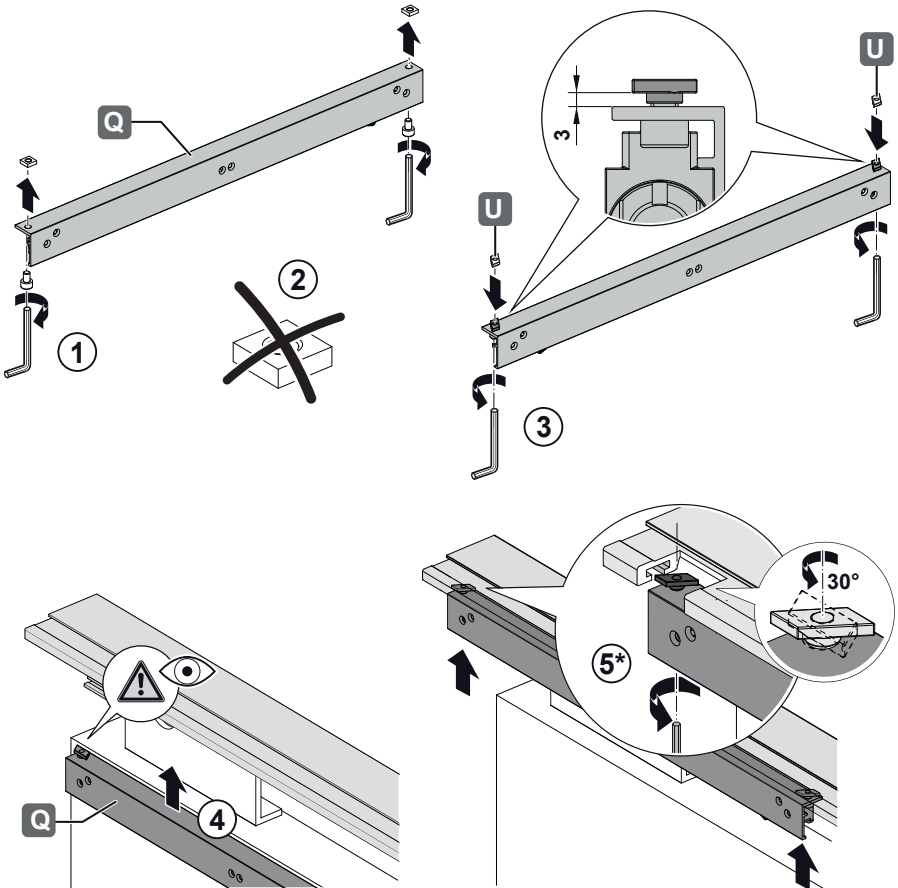

- * Nur leicht anziehen, der Dämpfer muss noch beweglich bleiben!
- * Only tighten slightly, the damper must still move!
- * Ne serrez que légèrement, l'amortisseur doit encore bouger !
- * Sólo apriete ligeramente, el amortiguador debe seguir moviéndose!

8.2

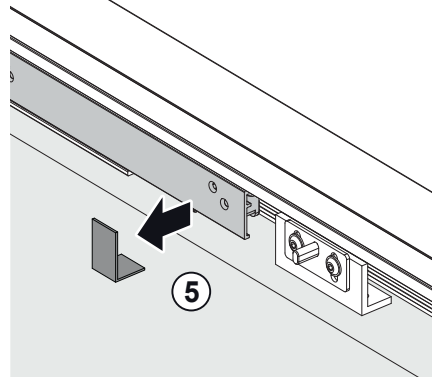
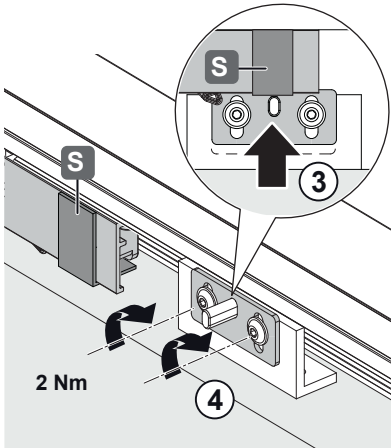
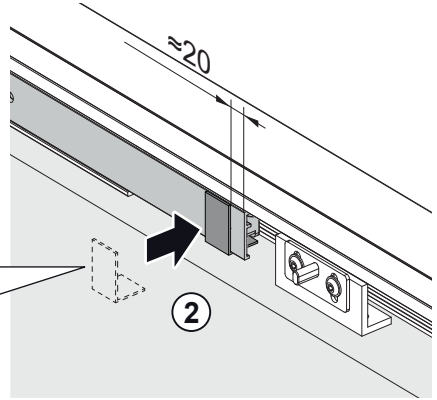
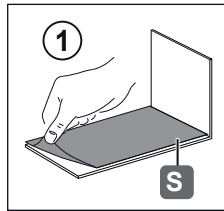

8.2

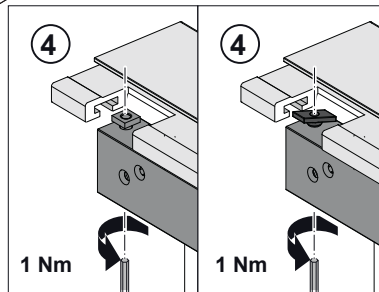
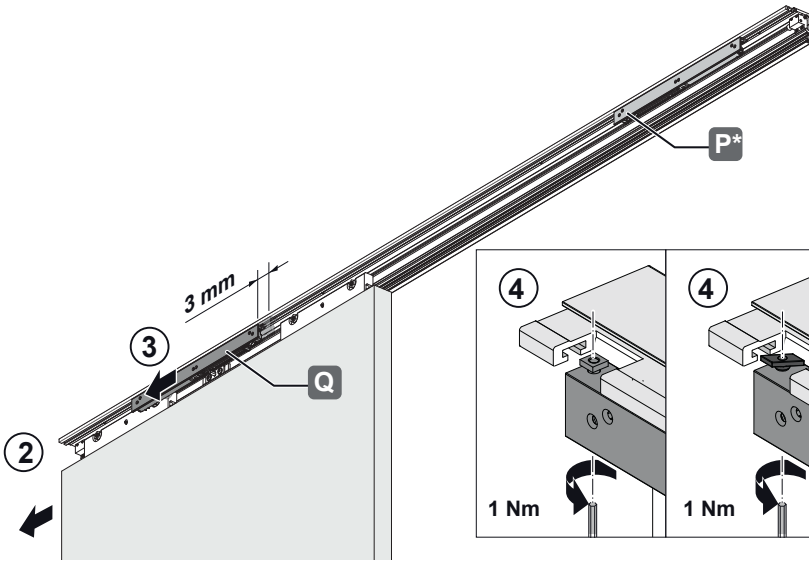
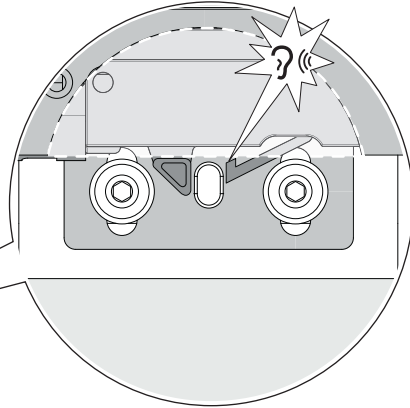
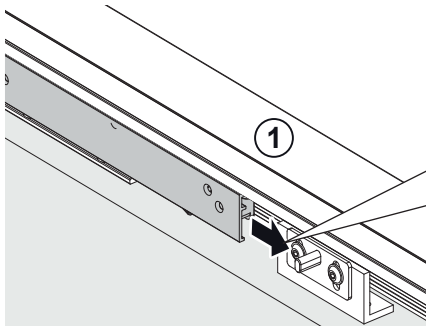
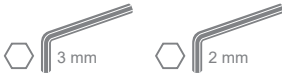

- * Zur Montage des zweiten Soft Closes die Montageschritte laut vorhergehenden Seiten wiederholen!
- * To assemble the second Soft Close, repeat the assembly steps on the previous pages!
- * Pour assembler le deuxième Soft Close, répétez les étapes d'assemblage des pages précédentes !
- * Para montar el segundo cierre suave, repita los pasos de montaje de las páginas anteriores.

8

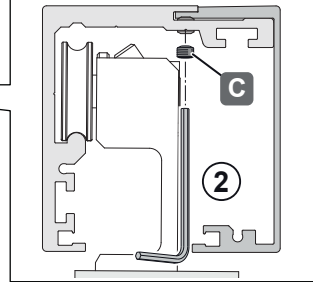
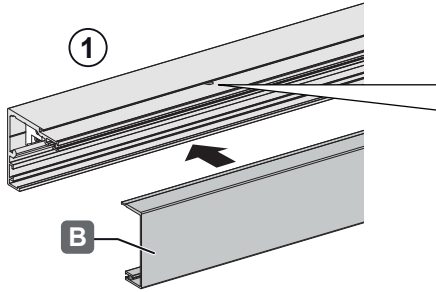

9

